



4-160-1201

Accelerometers

Accelerometer, Side Exit



Applications

- Light Industrial
- Gear Boxes
- Motors
- Bearing Housing
- Pumps

Features

- Two-wire, Current Driven
- Hermetically Sealed
- Electrical Isolated
- Single-Point Mounting
- Integral Cable Option

Description

The 4-160-1201 side exit accelerometer is designed for applications requiring a low profile sensor. Ideal for use in multi-point experimental or light industrial vibration monitoring applications.

The two-wire current loop operating principle permits very long interconnecting cables to be used where necessary and at minimum expense since standard screened pair (or multi-pair) cables may be used. The sensor is mounted by means of a single 1/4-28 captive bolt.

The piezoelectric sensor and amplifier are contained within an inner metal enclosure which is electrically and thermally insulated from the outer stainless steel body. This arrangement prevents ground loops and minimizes the effects of thermal shocks and base strain. The inner enclosure is connected to the 0V of the two-wire system and is therefore an effective electrical screen. External connections are made via a side exit integral cable or electrical connector.



4-160-1201 Accelerometer, Side Exit

Performance Specifications

Operation Voltage/Current:	18 to 28 VDC constant current source of 2-4 mA
Output Signal:	100 mV/g
Dynamic Range:	±50 g peak
Frequency Range:	2 Hz to 3 kHz (±5%) 1 Hz to 7 kHz (±10%) 0.5 Hz to 10 kHz (±3 dB)
Transverse Sensitivity:	Less than 5%
Amplitude Linearity:	±1% or better
Temperature Sensitivity:	Less than 5% to +250°F (+121°C)
Residual Electrical Noise:	Less than 0.1 mg (2 Hz to 21 kHz)
Signal Transmission:	2 wire system, electrically isolated from body up to 500 VAC
Output Impedance, Max.:	<100 ohm

Environmental

Acceleration Limit	
Vibration:	±50 g, peak
Shock:	5,000 g, peak
Temperature	
Operational:	-58°F to +250°F (-50°C to +121°C)
Storage:	-67°F to +302°F (-55°C to +150°C)
Environmental Sealing:	Sealed to IP67

Mechanical

Resonant Frequency:	21 kHz
Mounting:	1/4-28 captive bolt
Mounting Torque:	2 to 5 ft. lbs.
Weight:	5 oz. without cable
Case Material:	316L stainless steel

Optional Accessories

- Mating Connector P/N 619571-1004
- Cable assembly P/N 780400-91-XXXX (XXXX indicates length in inches e.g.: 10 ft cable = 120 inches is P/N 780400-91-0120). Assembly includes mating connector to prepared wire.

Ordering Information

Mating connectors and cable assemblies are not furnished and must be ordered separately. In keeping with CEC's policy of continuing product improvement, specifications may be changed without notice. See table for type numbers and available configurations.

NOTE: For submersed applications down to 100 ft., use model 4-160-2201-0X.

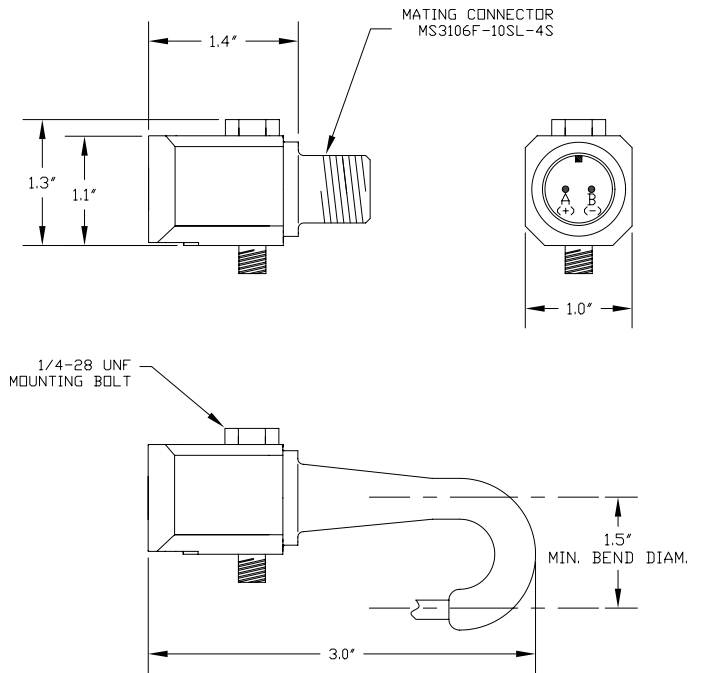

Type	Connection
4-160-1201	Side Connector
4-160-2201-01	Integral 10 ft. cable
4-160-2201-02	Integral 30 ft. cable
4-160-2201-03	Integral 50 ft. cable
4-160-2201-04	Integral 100 ft. cable